

EJOFAST[®] thin sheet metal screw JF3-2-5.5

Fastening components and brackets to thin-walled metal profiles

Self-drilling screws JF3/JT3

A2 stainless steel with hardened steel point / steel drill point

EJOT®

EJOFAST® thin sheet metal screw JF3-2-5.5

Ø [mm]	Length [mm]	Clamp thickness [mm]	PU	Price/100 [EUR]	Order description	Article number
Sealing washer E 16, Ø 16 mm						
5.5	25	0 - 7	500		JF3-2-5.5x25-E16*	3 597 211 391
5.5	35	0 - 17	500		JF3-2-5.5x35-E16*	3 597 511 391
*JF6 made of A4 stainless steel upon request						

Application area

Fastening components and brackets to thin-walled metal profiles for photovoltaic installations:

- Fastening trapezoidal sheet flashings, clips for fixing standing seam systems or pre-punched retainers to thin-walled steel substructure (e.g. profiled sheets)
- Fixing wind deflector sheets to profiled elements

Properties

- A2 stainless steel with innovative point geometry
- Stainless steel sealing washer
- Pre-assembled sealing washer
- Precise positioning
- Fastening without swarf and without pre-drilling
- Excellent clamping properties

Technical Data

Drilling capacity $t_1 + t_2$	1.0 + 1.0 mm
Drive	Hexagon AF8

www.ausschreiben.de

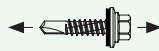
Minimum tensile strength	
	
Ø mm	kN
5.5	10.0

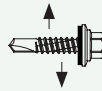
Minimum shear strength	
	
Ø mm	kN
5.5	7.5

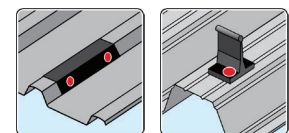

U

Approval
Z-14.4-426



Approval
ETA-10/0200

Cross reference

Accessories
Metal screwdriver SCS 6.3

Note

See relevant annexes of European technical approvals at the following pages.

Please download complete European technical approvals at our website:

www.ejot.es

Self-drilling screws JF3/JT3

A2 stainless steel with hardened steel point / steel drill point



Allgemeine bauaufsichtliche Zulassung
Nr. Z-14.4-426 vom 5. Dezember 2012

Deutsches
Institut
für
Bautechnik

DIBt

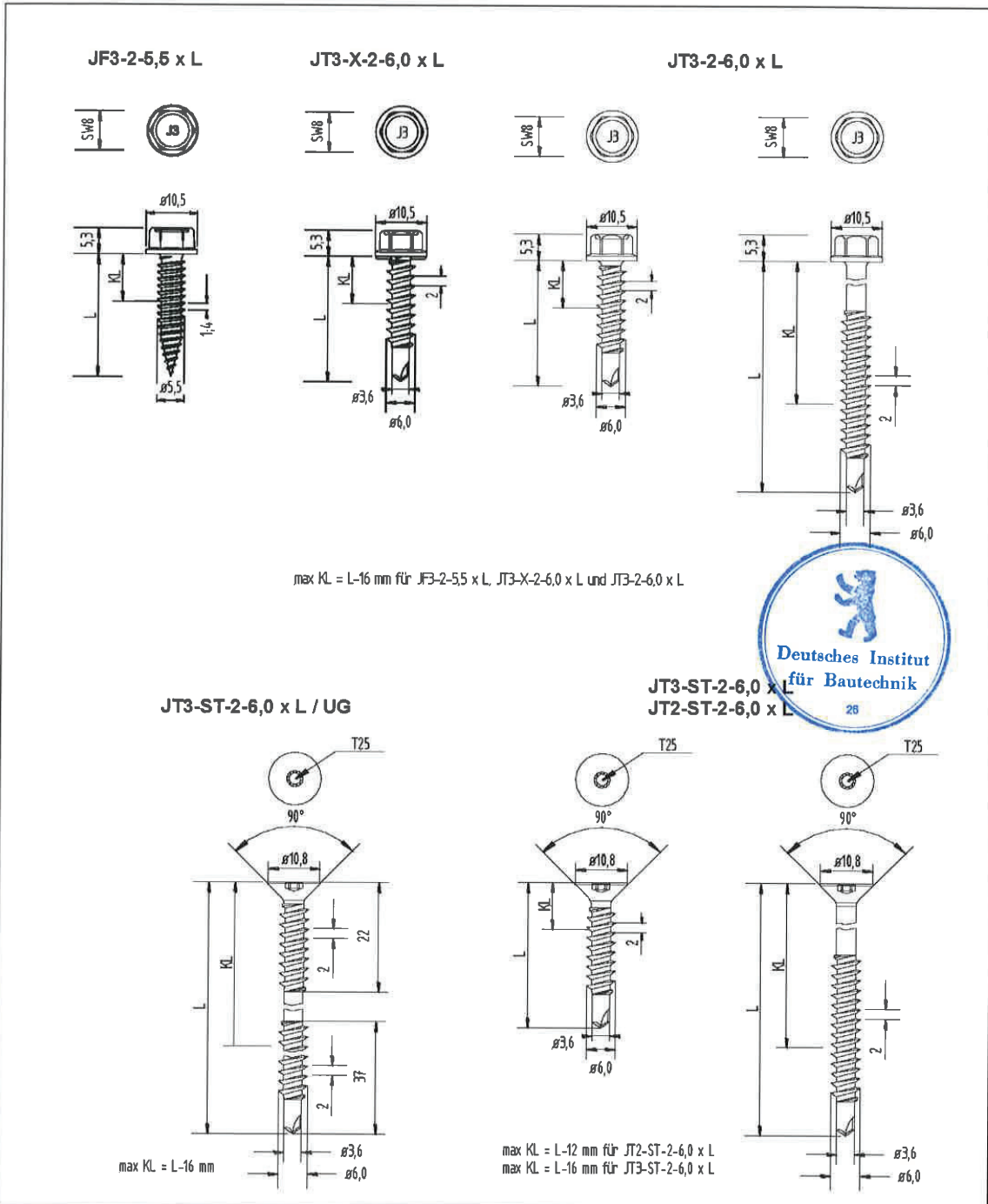

EJOT Bohrschrauben	Anlage 1
Geometrie und Abmessungen der Bohrschrauben JT2-ST-2-6,0 x L; JF3-2-5,5 x L; JT3-X-2-6,0 x L; JT3-2-6,0 x L; JT3-ST-2-6,0 x L; JT3-ST-2-6,0 x L/UG	

Z98325.12

1.14.4-58/11

Self-drilling screws JF3/JT3

A2 stainless steel with hardened steel point / steel drill point



Allgemeine bauaufsichtliche Zulassung
Nr. Z-14.4-426 vom 5. Dezember 2012

Deutsches
Institut
für
Bautechnik

DIBt

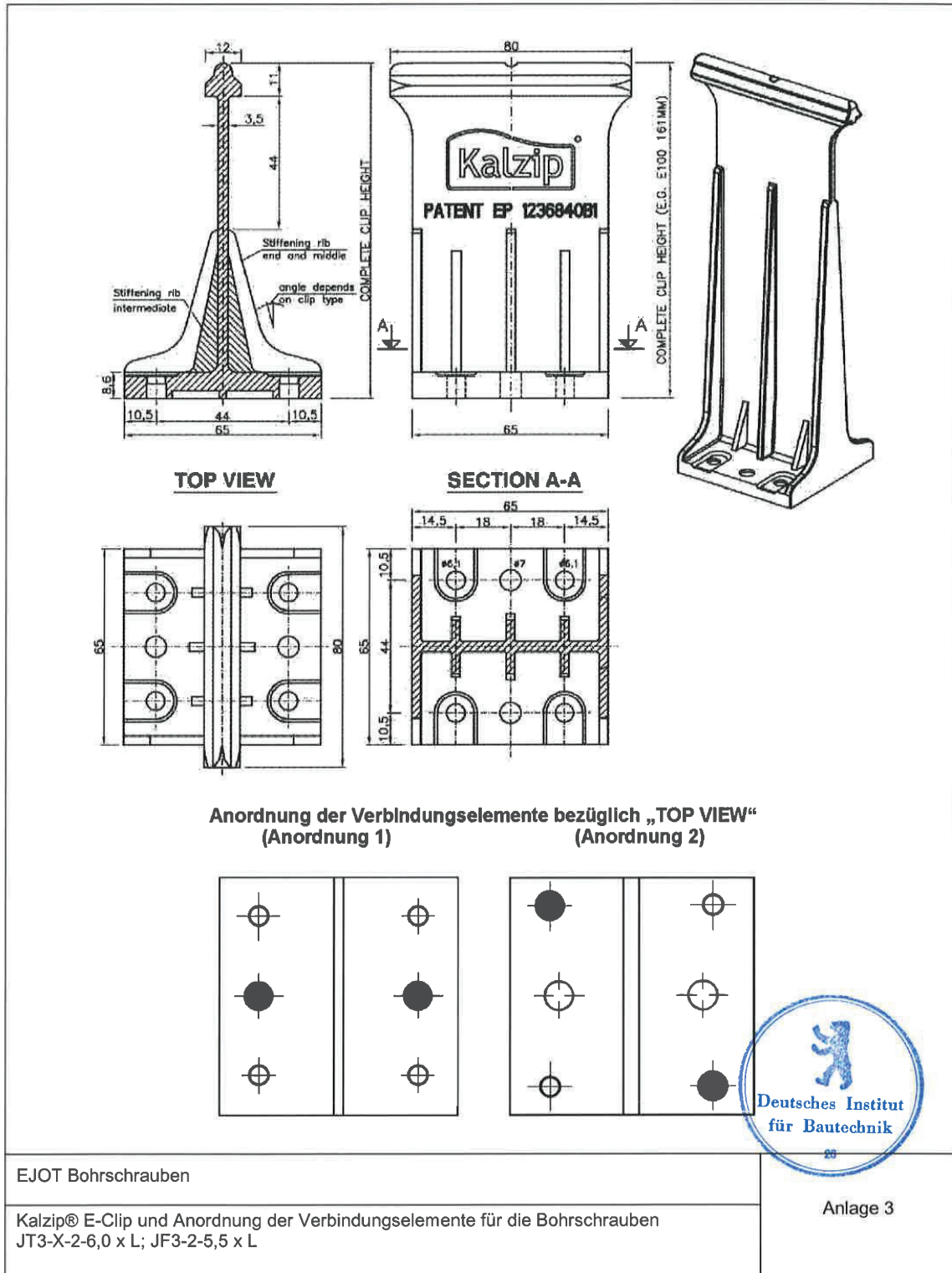

Self-drilling screws JF3/JT3

A2 stainless steel with hardened steel point / steel drill point



Allgemeine bauaufsichtliche Zulassung
Nr. Z-14.4-426 vom 5. Dezember 2012

Deutsches
Institut
für
Bautechnik

DIBt

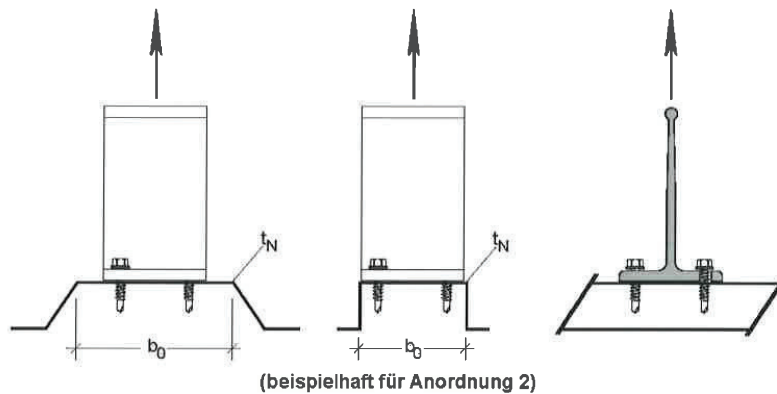

t_N [mm]	Stahlunterkonstruktionen								
	JF3-2-5,5 x L			JT3-X-2-6,0 x L					
	in Anordnung 1 oder 2 und mit $R_{m,min} =$			in Anordnung 1 und mit $R_{m,min} =$			in Anordnung 2 und mit $R_{m,min} =$		
	360 N/mm ²	390 N/mm ²	420 N/mm ²	360 N/mm ²	390 N/mm ²	420 N/mm ²	360 N/mm ²	390 N/mm ²	420 N/mm ²
0,75	2,60	2,91	3,23	1,91	2,23	2,52	1,91	2,32	2,69
0,88	3,32	3,69	4,07	2,59	2,87	3,09	2,79	3,15	3,44
1,00	4,01	4,44	4,87	3,06	3,26	3,39	3,40	3,66	3,83
1,13				3,36	3,44	3,78	3,92	3,92	
1,25				3,45		3,92			

Bei unsymmetrischen Unterkonstruktionen (Z- oder C-Profile) sind die angegebenen Werte um 30% zu reduzieren. Zwischenwerte dürfen linear interpoliert werden. gilt für: $b_0 / t_N \leq 275$

EJOT Bohrschrauben

Charakteristische Längszugtragfähigkeiten in kN von Klippbefestigungen mit Kalzip® E-Clip für die Bohrschrauben JT3-X-2-6,0 x L; JF3-2-5,5 x L

Anlage 5

Self-drilling screws JF3/JT3

A2 stainless steel with hardened steel point / steel drill point



Allgemeine bauaufsichtliche Zulassung
Nr. Z-14.4-426 vom 5. Dezember 2012

Deutsches
Institut
für
Bautechnik

DIBt

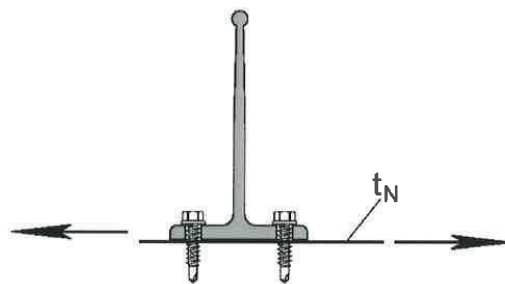

t_N [mm]	Aluminiumunterkonstruktionen						t_N [mm]	Stahlunterkonstruktionen					
	JT3-X-2-6,0 x L			JF3-2-5,5 x L				JT3-X-2-6,0 x L			JF3-2-5,5 x L		
	195	225	245	195	225	245		360	390	420	360	390	420
0,80	1,79	2,17	2,41	2,24	2,94	3,36	0,75	3,16	3,44	3,72	4,56	4,95	5,29
0,90	2,10	2,50	2,77	2,81	3,53	3,96	0,88	3,79	4,10	4,35	5,38	5,71	5,97
1,00							1,00				5,94		6,03
1,10	2,41	2,85	3,13	3,36	4,09	4,52	1,13	4,35				6,03	
1,20							1,25						



EJOT Bohrschrauben

Charakteristische Querkzugtragfähigkeiten in kN von Klippbefestigungen mit Kalzip® E-Clip für die Bohrschrauben JF3-2-5,5 x L; JT3-X-2-6,0 x L

Anlage 7

Z98333.12

1.14.4-58/11

Self-drilling screws JF3/JT3

A2 stainless steel with hardened steel point / steel drill point



Allgemeine bauaufsichtliche Zulassung
Nr. Z-14.4-426 vom 5. Dezember 2012

Deutsches
Institut
für
Bautechnik

DIBt

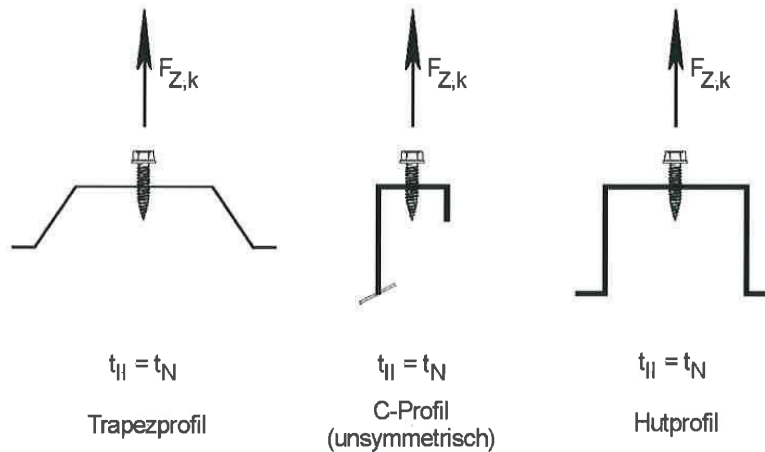

Stahlunterkonstruktionen			
t_N [mm]	mit $R_{m,min}$		
	360 N/mm ²	390 N/mm ²	420 N/mm ²
0,40	0,49	0,56	0,64
0,50	0,75	0,85	0,95
0,55	0,92	1,03	1,15
0,63	1,09	1,22	1,35
0,75	1,44	1,60	1,76
0,88	1,80	1,99	2,18
1,00	2,15	2,37	2,59
1,13	2,52	2,76	3,01
1,25	2,85	3,12	3,40

gilt für: $b_o / t_N \leq 275$
Bei unsymmetrischen Unterkonstruktionen (Z-, C- oder Σ -Profile) sind die angegebenen Werte $F_{Z,k}$ um 30% zu reduzieren.



EJOT Bohrschrauben

Charakteristische Auszugtragfähigkeiten in kN für die Bohrschraube JF3-2-5,5 x L

26

Anlage 9

Self-drilling screws JF3/JT3

A2 stainless steel with hardened steel point / steel drill point



Allgemeine bauaufsichtliche Zulassung
Nr. Z-14.4-426 vom 5. Dezember 2012

Deutsches
Institut
für
Bautechnik

DIBt



Stahlunterkonstruktionen			
t_N [mm]	mit $R_{m,min} =$		
	360 N/mm ²	390 N/mm ²	420 N/mm ²
0,40	0,61	0,70	0,78
0,50	0,88	0,97	1,06
0,55	1,04	1,13	1,23
0,63	1,18	1,29	1,42
0,75	1,51	1,69	1,92
0,88	1,99	2,34	2,79
1,00	2,71	3,34	4,13
1,13	3,84	4,91	5,34
1,25	5,34		

Am Schraubenkopf anliegendes Bauteil I aus Stahl oder Aluminium
mit $t_N \geq 5,0$ mm, vorgebohrt oder vorgestanzt mit $\varnothing 6,1$ mm



EJOT Bohrschrauben

Charakteristische Querkzugtragfähigkeiten in kN für die Bohrschraube JF3-2-5,5 x L

Anlage 12

Z98340.12

1.14.4-58/11

Self-drilling screws JF3/JT3

A2 stainless steel with hardened steel point / steel drill point



Allgemeine bauaufsichtliche Zulassung
Nr. Z-14.4-426 vom 5. Dezember 2012

Deutsches
Institut
für
Bautechnik

DIBt

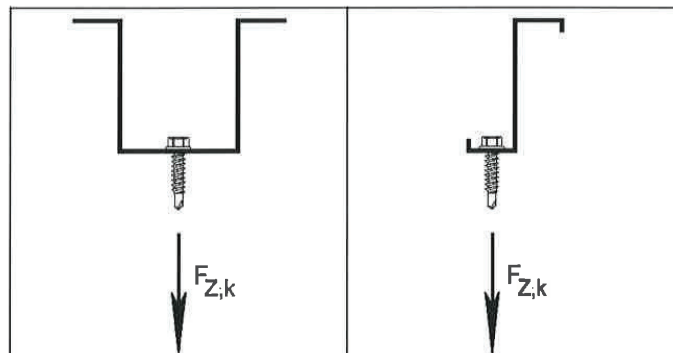

Aluminium mit $R_m \geq 190 \text{ N/mm}^2$	2,47 kN	2,22 kN
Stahl mit $R_m \geq 360 \text{ N/mm}^2$	8,24 kN	7,42 kN
Bauteil I aus Stahl oder Aluminium mit $t_1 \geq 1,50$ Wird Bauteil I unmittelbar durch Windsog beansprucht, sind die Werte auf 67% abzumindern.		



EJOT Bohrschrauben

Charakteristische Längszugtragfähigkeiten in kN für die Bohrschrauben
JF3-2-5,5 x L; JT3-X-2-6,0 x L; JT3-2-6,0 x L

Anlage 15

Self-drilling screws JF3/JT3

A2 stainless steel with hardened steel point / steel drill point



Page 108 of European technical approval
ETA-10/0200 of 27 June 2013

English translation prepared by DIBt

Deutsches
Institut
für
Bautechnik

DIBt

Materials

Fastener: stainless steel (1.4301 / 1.4567) – EN 10088
stainless steel (1.4401 / 1.4578) – EN 10088

Washer: stainless steel (1.4301) – EN 10088

Component I: S280GD, S320GD or S350GD – EN 10346

Component II: S280GD, S320GD or S350GD – EN 10346

Drilling capacity $\Sigma t_i \leq 2 \times 1,00 \text{ mm}$

Timber substructures
for timber substructures no performance determined

$t_{N,II} =$	0,40	0,50	0,55	0,63	0,75	0,88	1,00
$M_{t,rom} =$	—						
$V_{R,k}$ for $t_{N,I} =$	0,40	0,88 —	0,88 —	0,88 —	0,88 —	0,88 —	0,88 —
	0,50	0,88 —	1,56 —	1,56 —	1,56 —	1,56 —	1,56 —
	0,55	0,88 —	1,56 —	1,76 —	1,76 —	1,76 —	1,76 —
	0,63	0,88 —	1,56 —	1,76 —	2,09 —	2,09 —	2,09 —
	0,75	0,88 —	1,56 —	1,76 —	2,09 —	2,57 —	2,57 —
	0,88	0,88 —	1,56 —	1,76 —	2,09 —	2,57 —	3,11 —
	1,00	0,88 —	1,56 —	1,76 —	2,09 —	2,57 —	3,11 —
	1,13	—	—	—	—	—	—
1,25	—	—	—	—	—	—	
$N_{R,k}$ for $t_{N,I} =$	0,40	0,60 —	0,82 —	0,94 —	1,00 —	1,00 —	1,00 —
	0,50	0,60 —	0,82 —	0,94 —	1,14 —	1,44 —	1,67 —
	0,55	0,60 —	0,82 —	0,94 —	1,14 —	1,44 —	1,80 —
	0,63	0,60 —	0,82 —	0,94 —	1,14 —	1,44 —	1,80 —
	0,75	0,60 —	0,82 —	0,94 —	1,14 —	1,44 —	1,80 —
	0,88	0,60 —	0,82 —	0,94 —	1,14 —	1,44 —	1,80 —
	1,00	0,60 —	0,82 —	0,94 —	1,14 —	1,44 —	1,80 —
	1,13	—	—	—	—	—	—
1,25	—	—	—	—	—	—	

If both components I and II are made of S320GD or S350GD all values may be increased by 8,3%.

Self drilling screw		Annex 95
JF3-2-5,5 x L	JF6-2-5,5 x L	
JF3-FR-2-5,5 x L	JF6-FR-2-5,5 x L	
with hexagon head or round head with Torx®-drive and sealing washer $\ge \varnothing 11 \text{ mm}$		

Self-drilling screws JF3/JT3

A2 stainless steel with hardened steel point / steel drill point



Page 109 of European technical approval
ETA-10/0200 of 27 June 2013

English translation prepared by DIBt

Deutsches
Institut
für
Bautechnik

DIBt

Materials

Fastener: stainless steel (1.4301 / 1.4567) – EN 10088
stainless steel (1.4401 / 1.4578) – EN 10088

Washer: stainless steel (1.4301) – EN 10088

Component I: S280GD, S320GD or S350GD – EN 10346
Component II: S280GD, S320GD or S350GD – EN 10346

Drilling capacity $\Sigma t_i \leq 2 \times 1,00 \text{ mm}$

Timber substructures
for timber substructures no performance determined

$t_{N,II} =$	0,40	0,50	0,55	0,63	0,75	0,88	1,00
$M_{t,rom} =$	—						
$N_{R,k}$ for $t_{N,I} =$	0,40	0,96 —	0,96 —	0,96 —	0,96 —	0,96 —	0,96 —
	0,50	0,96 —	1,56 —	1,56 —	1,56 —	1,56 —	1,56 —
	0,55	0,96 —	1,56 —	1,76 —	1,76 —	1,76 —	1,76 —
	0,63	0,96 —	1,56 —	1,76 —	2,09 —	2,09 —	2,09 —
	0,75	0,96 —	1,56 —	1,76 —	2,09 —	2,57 —	2,57 —
	0,88	0,96 —	1,56 —	1,76 —	2,09 —	2,57 —	3,11 —
	1,00	0,96 —	1,56 —	1,76 —	2,09 —	2,57 —	3,11 —
	1,13	—	—	—	—	—	—
1,25	—	—	—	—	—	—	
$N_{R,k}$ for $t_{N,I} =$	0,40	0,60 —	0,82 —	0,94 —	1,14 —	1,44 —	1,46 —
	0,50	0,60 —	0,82 —	0,94 —	1,14 —	1,44 —	1,76 —
	0,55	0,60 —	0,82 —	0,94 —	1,14 —	1,44 —	1,80 —
	0,63	0,60 —	0,82 —	0,94 —	1,14 —	1,44 —	1,80 —
	0,75	0,60 —	0,82 —	0,94 —	1,14 —	1,44 —	1,80 —
	0,88	0,60 —	0,82 —	0,94 —	1,14 —	1,44 —	1,80 —
	1,00	0,60 —	0,82 —	0,94 —	1,14 —	1,44 —	1,80 —
	1,13	—	—	—	—	—	—
1,25	—	—	—	—	—	—	

If both components I and II are made of S320GD or S350GD all values may be increased by 8,3%.

Self drilling screw	Annex 96
JF3-2-5,5 x L JF6-2-5,5 x L JF3-FR-2-5,5 x L JF6-FR-2-5,5 x L	
with hexagon head or round head with Torx®-drive and sealing washer $\geq \varnothing 14 \text{ mm}$	

Self-drilling screws JF3/JT3

A2 stainless steel with hardened steel point / steel drill point



Page 110 of European technical approval
ETA-10/0200 of 27 June 2013

English translation prepared by DIBt

Deutsches
Institut
für
Bautechnik

DIBt

Materials

Fastener: stainless steel (1.4301 / 1.4567) – EN 10088
stainless steel (1.4401 / 1.4578) – EN 10088

Washer: stainless steel (1.4301) – EN 10088

Component I: aluminium-Alloy
with $R_{m,min} = 165 \text{ N/mm}^2$ – EN 573

Component II: aluminium-Alloy
with $R_{m,min} = 165 \text{ N/mm}^2$ – EN 573

Drilling capacity $\Sigma t_i \leq 2 \times 1,50 \text{ mm}$

Timber substructures
for timber substructures no performance determined

$t_{N,II} =$	0,40	0,50	0,60	0,70	0,80	0,90	1,00	1,20	1,50		
$M_{t,thom} =$	—										
$V_{R,k} \text{ for } t_{N,I} =$	0,40	0,43	—	0,43	—	0,43	—	0,43	—	0,43	—
	0,50	0,43	—	0,62	—	0,62	—	0,62	—	0,62	—
	0,60	0,43	—	0,62	—	0,71	—	0,71	—	0,71	—
	0,70	0,43	—	0,62	—	0,71	—	0,79	—	0,79	—
	0,80	0,43	—	0,62	—	0,71	—	0,79	—	0,88	—
	0,90	0,43	—	0,62	—	0,71	—	0,79	—	0,88	—
	1,00	0,43	—	0,62	—	0,71	—	0,79	—	0,88	—
$N_{R,III} =$	1,20	0,43	—	0,62	—	0,71	—	0,79	—	0,88	—
	1,50	0,43	—	0,62	—	0,71	—	0,79	—	0,88	—
		0,24	0,35	0,45	0,58	0,69	0,80	0,91	1,13	1,63	

Pull-through resistance of component I according to EN 1999-1-4, section 8.3.3.1 or specifications of the manufacturer of the aluminium structural sheeting.

self drilling screw

JF3-2-5,5 x L JF6-2-5,5 x L
JF3-FR-2-5,5 x L JF6-FR-2-5,5 x L

with hexagon head or round head with Torx®-drive and sealing washer $\geq \varnothing 11 \text{ mm}$

Annex 97

Self-drilling screws JF3/JT3

A2 stainless steel with hardened steel point / steel drill point



Page 111 of European technical approval
ETA-10/0200 of 27 June 2013

English translation prepared by DIBt

Deutsches
Institut
für
Bautechnik

DIBt

Materials

Fastener: stainless steel (1.4301) – EN 10088
stainless steel (1.4404) – EN 10088

Washer: stainless steel (1.4301) – EN 10088

Component I: aluminium-Alloy
with $R_{m,min} = 215 \text{ N/mm}^2$ – EN 573

Component II: aluminium-Alloy
with $R_{m,min} = 215 \text{ N/mm}^2$ – EN 573

Drilling capacity $\Sigma t_i \leq 2 \times 1,50 \text{ mm}$

Timber substructures
for timber substructures no performance determined

$t_{N,II} =$	0,40	0,50	0,60	0,70	0,80	0,90	1,00	1,20	1,50	
$M_{t,thom} =$	—									
$V_{R,k} \text{ for } t_{N,I} =$	0,40	0,55	—	0,55	—	0,55	—	0,55	—	0,55
	0,50	0,55	—	0,79	—	0,79	—	0,79	—	0,79
	0,60	0,55	—	0,79	—	0,91	—	0,91	—	0,91
	0,70	0,55	—	0,79	—	0,91	—	1,03	—	1,03
	0,80	0,55	—	0,79	—	0,91	—	1,03	—	1,15
	0,90	0,55	—	0,79	—	0,91	—	1,03	—	1,15
	1,00	0,55	—	0,79	—	0,91	—	1,03	—	1,15
	1,20	0,55	—	0,79	—	0,91	—	1,03	—	1,15
$N_{R,III} =$	1,50	0,55	—	0,79	—	0,91	—	1,03	—	1,15
		0,31		0,46		0,60		0,75		0,89
								1,04		1,18
										1,47
										2,12

Pull-through resistance of component I according to EN 1999-1-4, section 8.3.3.1 or specifications of the manufacturer of the aluminium structural sheeting.

self drilling screw

JF3-2-5,5 x L JF6-2-5,5 x L
JF3-FR-2-5,5 x L JF6-FR-2-5,5 x L

with hexagon head or round head with Torx®-drive and sealing washer $\geq \varnothing 11 \text{ mm}$

Annex 98